



### Model Number

NCB50-FP-E2-P1

### Features

- 50 mm flush
- 3-wire DC

## Technical Data

### General specifications

Switching element function	PNP NO contact
Rated operating distance	$s_n$ 50 mm
Installation	flush
Output polarity	DC
Assured operating distance	$s_a$ 0 ... 40.5 mm
Reduction factor $r_{Al}$	0.38
Reduction factor $r_{Cu}$	0.35
Reduction factor $r_{304}$	0.83

### Nominal ratings

Operating voltage	$U_B$	10 ... 60 V DC
Switching frequency	$f$	0 ... 80 Hz
Hysteresis	$H$	typ. 3 %
Reverse polarity protection		reverse polarity protected
Short-circuit protection		pulsing
Voltage drop	$U_d$	$\leq 3$ V
Operating current	$I_L$	0 ... 200 mA
Off-state current	$I_r$	0 ... 0.5 mA
No-load supply current	$I_0$	$\leq 20$ mA
Time delay before availability	$t_v$	$\leq 300$ ms
Operating voltage indicator		LED, green
Switching state indicator		LED, yellow

### Functional safety related parameters

MTTF <sub>d</sub>	940 a
Mission Time ( $T_M$ )	20 a
Diagnostic Coverage (DC)	0 %

### Ambient conditions

Ambient temperature	-25 ... 70 °C (-13 ... 158 °F)
---------------------	--------------------------------

### Mechanical specifications

Connection type	screw terminals
Information for connection	A maximum of two conductors with the same core cross-section may be mounted on one terminal connection! tightening torque 1.2 Nm + 10 %
Core cross-section	up to 2.5 mm <sup>2</sup>
Minimum core cross-section	without wire end ferrule 0.5 mm <sup>2</sup> , with connector sleeves 0.34 mm <sup>2</sup>
Maximum core cross-section	without wire end ferrule 2.5 mm <sup>2</sup> , with connector sleeves 1.5 mm <sup>2</sup>
Housing material	PBT
Sensing face	PBT
Housing base	PBT
Degree of protection	IP68

### Compliance with standards and directives

Standard conformity	
Standards	EN 60947-5-2:2007 IEC 60947-5-2:2007

### Approvals and certificates

EAC conformity	TR CU 020/2011
UL approval	cULus Listed, General Purpose
CSA approval	cCSAus Listed, General Purpose
CCC approval	Certified by China Compulsory Certification (CCC)

## Dimensions

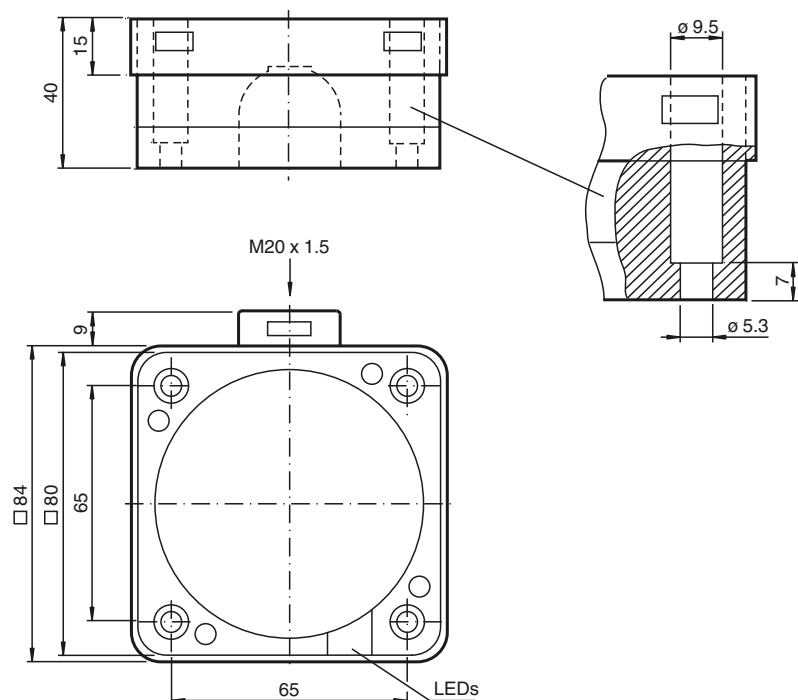

## Electrical Connection

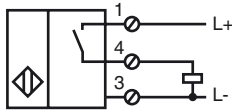

## Installation Hint

These sensors are especially designed for embeddable mounting in conveyor floors. Due to its precise location in metal base plates the sensor is afforded a high degree of mechanical protection. No clearance is required between the sensor and the base plate, avoiding the need for protective guarding to prevent possible foot injury.

The large sensing range ensures positive detection, and thus provides consistent control and monitoring of the conveyor.

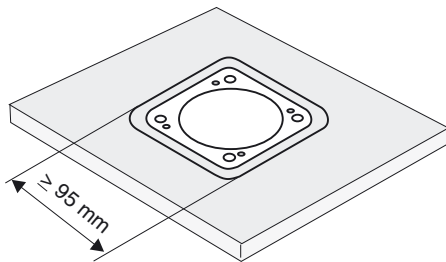

**Warning!**  
Once the metal screening has been removed, the sensor can no longer be embeddable mounted.